

4 étages  
4 steps  
4 Stufen

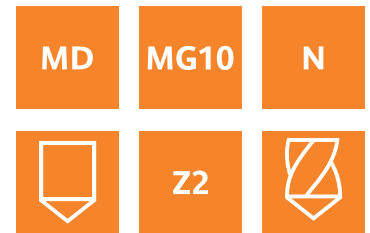
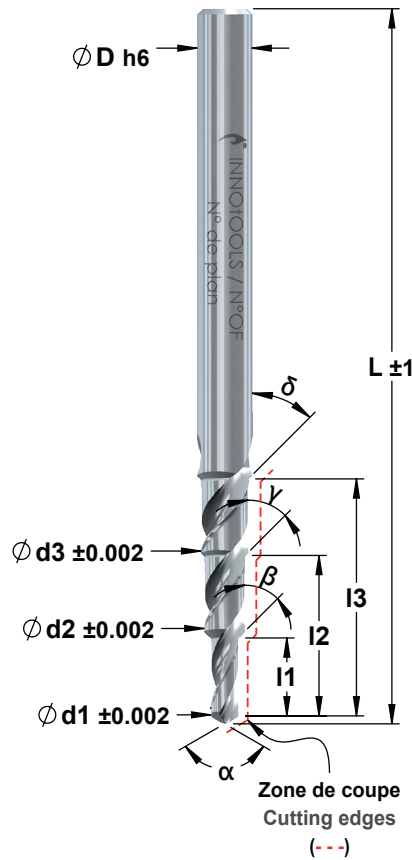

Demande de prix  
Price request  
Preis Anfrage

Commande  
Order  
Bestellung

Droite  
Right  
Recht

Gauche  
Left  
links

Ød1 \_\_\_\_\_ I1 \_\_\_\_\_ α \_\_\_\_\_ °  
 Ød2 \_\_\_\_\_ I2 \_\_\_\_\_ β \_\_\_\_\_ °  
 Ød3 \_\_\_\_\_ I3 \_\_\_\_\_ γ \_\_\_\_\_ °  
 ØDh6 \_\_\_\_\_ L \_\_\_\_\_ δ \_\_\_\_\_ °

Métal dur  
Solid Carbide  
VHM

Quantité  
Quantity  
Quantität \_\_\_\_\_

Matière à usiner  
Material to be machined  
Werkstoff zum Bearbeiten \_\_\_\_\_

Revêtement / Coating / Beschichtungen

TiAlN (Acier doux, inox / Mild steel, Stainless steel / Stahl, Inox)  
 AlTiN (Aciers difficiles / Tough steel / Heikle Stähle)  
 AlTiCrN (Alu, cuivre, titane / Alu, copper, Titan / Alu, Kupfer, Titan)  
 Autre  
Other  
Andere \_\_\_\_\_