

2 étages
2 steps
2 Stufen

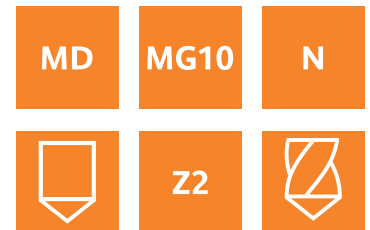
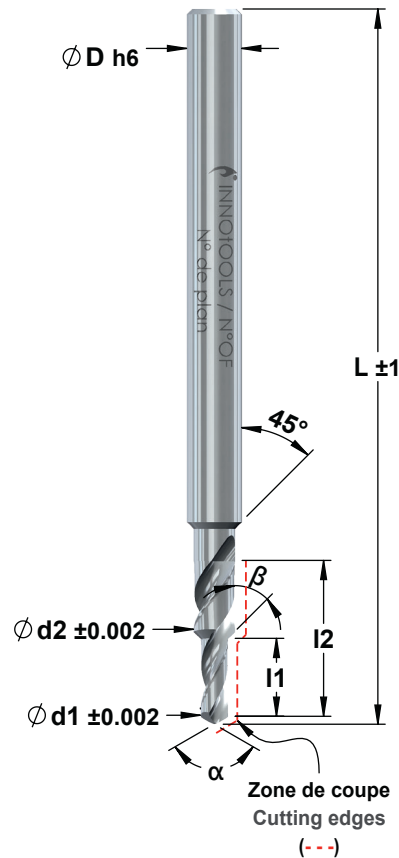

Demande de prix
Price request
Preis Anfrage

Commande
Order
Bestellung

Droite
Right
Recht

Gauche
Left
links

$\varnothing d1$ _____ $l1$ _____ α _____ °

$\varnothing d2$ _____ $l2$ _____ β _____ °

$\varnothing Dh6$ _____ L _____

Métal dur
Solid Carbide
VHM

Quantité
Quantity
Quantität _____

Matière à usiner
Material to be machined
Werkstoff zum Bearbeiten _____

Revêtement / Coating / Beschichtungen

- TiAlN (Acier doux, inox / Mild steel, Stainless steel / Stahl, Inox)
 AlTiN (Aciers difficiles / Tough steel / Heikle Stähle)
 AlTiCrN (Alu, cuivre, titane / Alu, copper, Titan / Alu, Kupfer, Titan)
 Autre
Other
Andere _____