

1 étage
1 step
1 Stufe

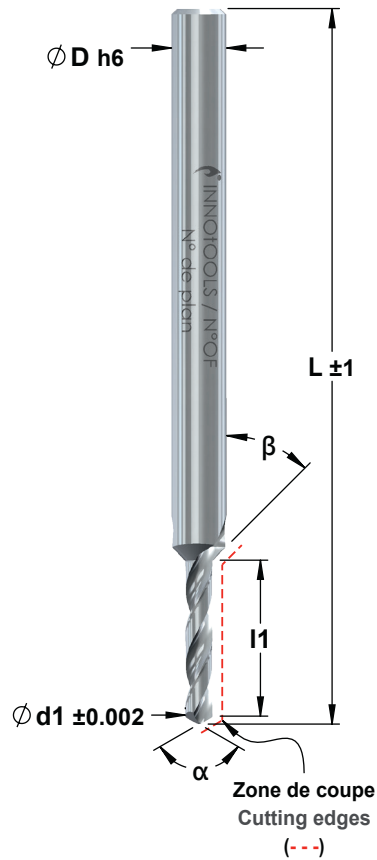

MD	MG10	N
	Z2	

Demande de prix
Price request
Preis Anfrage

Commande
Order
Bestellung

Droite
Right
Recht

Gauche
Left
links

Ød1 _____ l1 _____ α _____ °
ØDh6 _____ L _____ β _____ °

Métal dur
Solid Carbide
VHM

Quantité
Quantity
Quantität _____

Matière à usiner
Material to be machined
Werkstoff zum Bearbeiten _____

Revêtement / Coating / Beschichtungen

- TiAlN (Acier doux, inox / Mild steel, Stainless steel / Stahl, Inox)
- AlTiN (Aciers difficiles / Tough steel / Heikle Stähle)
- AlTiCrN (Alu, cuivre, titane / Alu, copper, Titan / Alu, Kupfer, Titan)
- Autre
Other
Andere _____