

à rayon convexe
Convex radius
Mit Radius Konvex

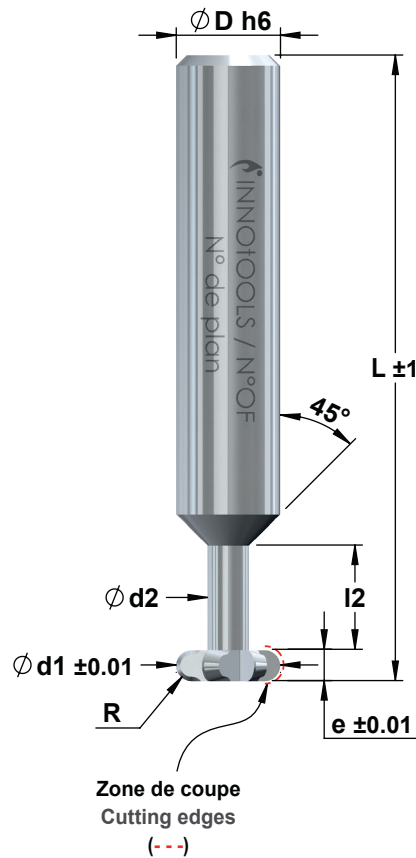

MD MG10	N	6-14° Y
U	0° λ	U →



Demande de prix
Price request
Preisanfrage

Commande
Order
Bestellung

Ød1 _____ e _____ R _____

Ød2 _____ l2 _____ Z _____

ØDh6 _____ L _____

Quantité
Quantity
Quantität _____

Matière à usiner
Material to be machined
Werkstoff zum Bearbeiten _____

Revêtement / Coating / Beschichtungen

- TiAlN (Acier doux, inox / Mild steel, Stainless steel / Stahl, Inox)
- AlTiN (Aciers difficiles / Tough steel / Heikle Stähle)
- AlTiCrN (Alu, cuivre, titane / Alu, copper, Titan / Alu, Kupfer, Titan)
- Autre
Other
Andere _____