

**Burins POSALUX**  
**POSALUX turning tools**  
**POSALUX Drehmeissel**

**Exécution sur mesure**  
**Custom-made design**  
**Ausführung auf Mass**

**1830 SP**

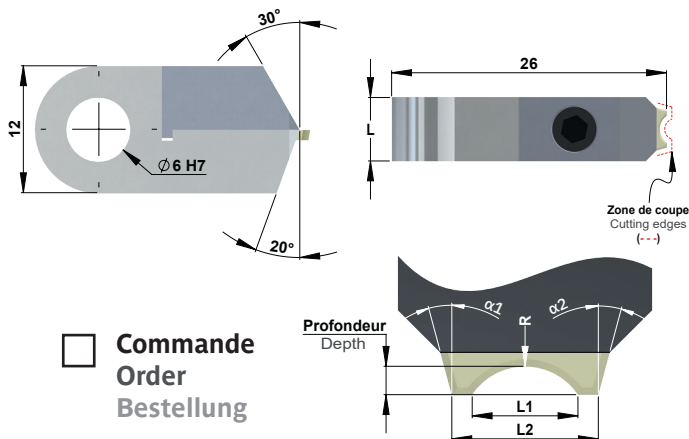
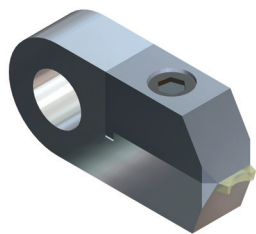

**Demande de prix**  
**Price request**  
**Preis Anfrage**

**Commande**  
**Order**  
**Bestellung**

L1 \_\_\_\_\_ L2 \_\_\_\_\_ **Profondeur** \_\_\_\_\_

$\alpha 1$  \_\_\_\_\_ °  $\alpha 2$  \_\_\_\_\_ ° L \_\_\_\_\_ R \_\_\_\_\_

**Matière à usiner**  
**Material to be machined**  
**Werkstoff zum Bearbeiten** \_\_\_\_\_

**Quantité**  
**Quantity**  
**Quantität** \_\_\_\_\_

**Diamant MCD**  
**Forme concave**  
**Monocrystalline**  
**Diamond**  
**Concave**  
**Monokristalliner**  
**Diamant**  
**Konkav Form**



**Burins POSALUX**  
**POSALUX turning tools**  
**POSALUX Drehmeissel**

**Exécution sur mesure**  
**Custom-made design**  
**Ausführung auf Mass**

**1840 SP**

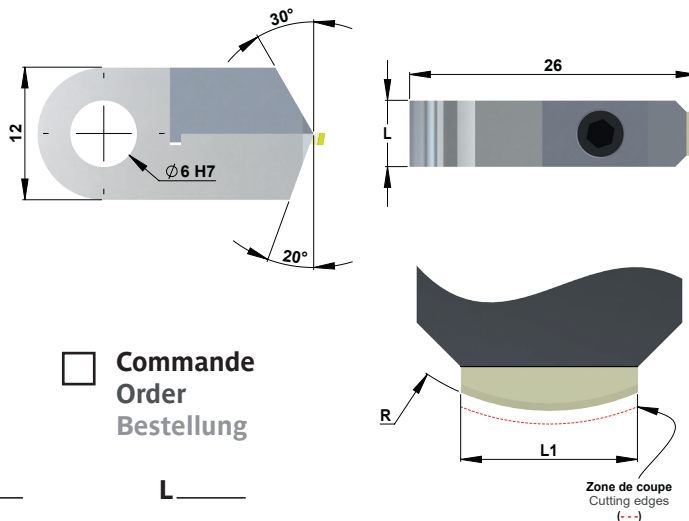
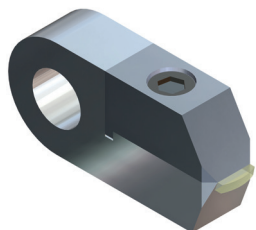

**Demande de prix**  
**Price request**  
**Preis Anfrage**

**Commande**  
**Order**  
**Bestellung**

L1 \_\_\_\_\_ R \_\_\_\_\_ L \_\_\_\_\_

**Matière à usiner**  
**Material to be machined**  
**Werkstoff zum Bearbeiten** \_\_\_\_\_

**Quantité**  
**Quantity**  
**Quantität** \_\_\_\_\_

**Diamant MCD**  
**Forme convexe**  
**Monocrystalline**  
**Diamond**  
**Convex**  
**Monokristalliner**  
**Diamant**  
**Konvexe Form**

