

Fraises hémisphériques
End mills with ball end
Halbkugelfräser (sphärisch)

4900

Diamant MCD
Pour moulure
 Monocristalline
 Diamond
 For moulding
 Monokristalliner
 Diamant
 Für Formen

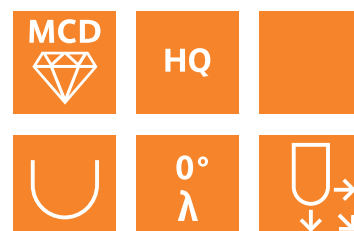

Ød1	R	L1 max	L2 min	L	ØDh6
1.00	0.50	1	0.15	39	6
1.00	0.60	1	0.20	39	6
1.00	0.70	1	0.20	39	6
1.50	0.80	1.5	0.20	39	6
1.50	0.90	1.5	0.30	39	6
2.00	1.00	2	0.30	39	6
2.00	1.10	2	0.30	39	6
2.00	1.20	2	0.30	39	6
2.00	1.30	2	0.30	39	6
2.00	1.40	2	0.30	39	6
2.00	1.50	2	0.30	39	6
2.00	1.60	2	0.30	39	6
2.00	1.70	2	0.30	39	6
2.50	3.00	2.5	0.30	39	6
3.00	1.80	3	0.30	39	6
3.00	1.90	3	0.30	39	6
3.00	2.00	3	0.30	39	6
3.00	2.50	3	0.30	39	6
3.00	3.00	3	0.30	39	6
3.00	3.50	3	0.30	39	6
4.00	4.00	4	0.30	39	6
4.00	5.00	4	0.30	39	6

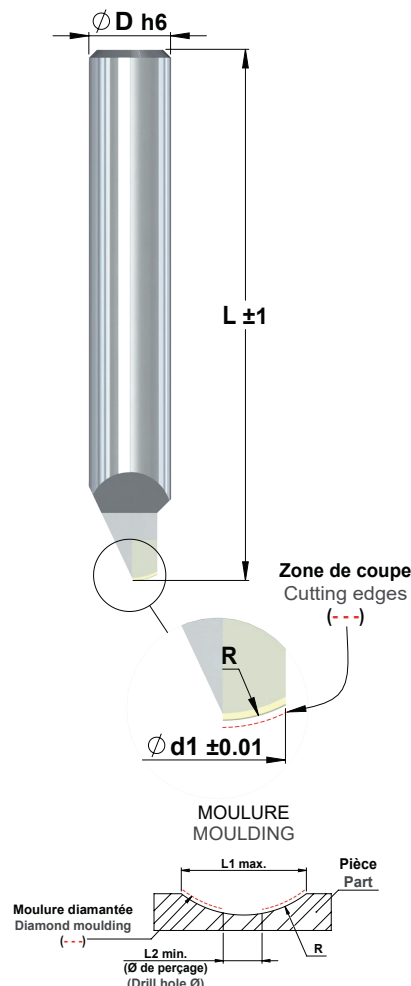

Fraises hémisphériques
End mills with ball end
Halbkugelfräser (sphärisch)

Exécution sur mesure
Custom-made design
Ausführung auf Mass

4900 SP

Demande de prix
 Price request
 Preisanfrage

Commande
 Order
 Bestellung



Diamant MCD
Pour moulure
 Monocristalline
 Diamond
 For moulding
 Monokristalliner
 Diamant
 Für Formen

Ød1 _____ R _____ L1 max _____

L2 min _____ L _____ ØDh6 _____

Matière à usiner _____ **Quantité** _____
 Material to be machined _____ Quantity _____
 Werkstoff zum Bearbeiten _____ Quantität _____

